

Blue Print Top Tip

Mazda / Ford - Timing Alignment Pin Set

Applicable References: ADM55501, ADM57535, ADM57537, ADK87617, ADP157601

Applications: Various Mazda and Ford models fitted with 1.4TDCi and 1.6TDCi engines

Date Issued: 03/2011

Blue Print's 'Timing Alignment Pin Set' ADM55501 is required to allow correct engine timing alignment which is vital when removing/replacing the timing belt on Mazda and Ford vehicles fitted with 1.4TDCi and 1.6TDCi engines.

Note: Blue Print 'Timing Alignment Pin Set' - ADM55501 - is for use on both SOHC and DOHC applications. On DOHC applications the timing belt drives one camshaft at the front of the engine. The second camshaft is driven by the first camshaft by means of an additional timing chain at the rear of the engine.

ADM55501



Pin 'A' is a crankshaft locking pin:

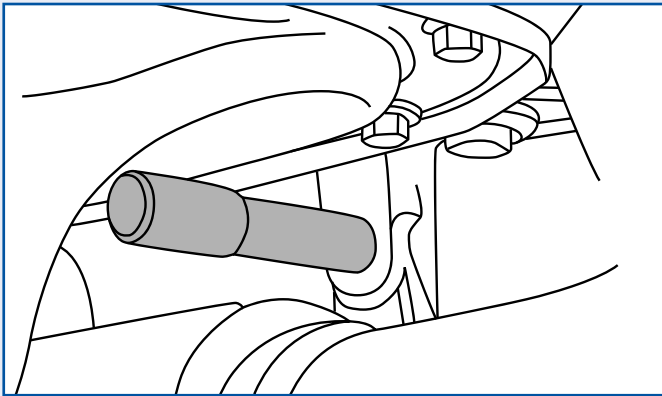

Pin 'A' is used to lock the crankshaft by locating in the back of the flywheel, allowing the crankshaft bolt to be loosened/re-tightened.

Pin 'B' is a camshaft sprocket alignment pin:

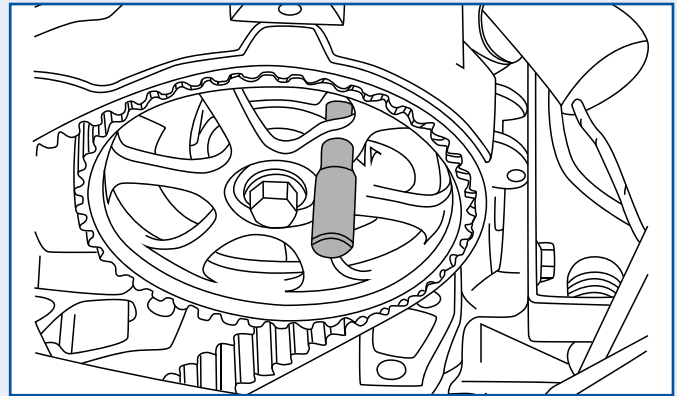

Pin 'B' is used to locate the camshaft sprocket and ensure it does not move during timing belt removal and installation.

Pin 'C' is a crankshaft/injection pump sprocket alignment pin:

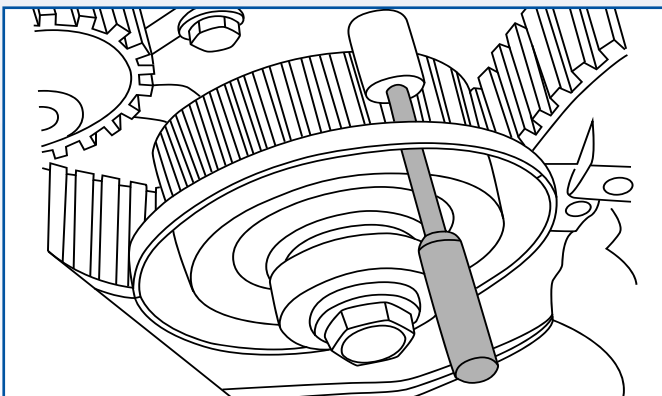

Pin 'C' is used twice during the timing belt replacement process, and is used to align both the crankshaft and injection pump sprockets.

Failure to use the correct tools and adhere to the correct instructions could result in severe engine damage.

We recommend that you do not attempt timing belt replacement unless you have the full manufacturer's instructions for performing the maintenance/repair.

Disclaimer : Any technical tips are produced in good faith. Ferdinand Bilstein UK Ltd. always recommend that vehicle maintenance and diagnostics are only carried out by suitably experienced people using appropriate tools in a safe manner within a workshop environment. Ferdinand Bilstein UK Ltd. and their customers cannot be held responsible for the correctness of, or misinterpretation of the above technical tips. Images shown are for illustrative purposes only and may not be representative of the products or vehicles described.



www.blue-print.com

Blue Print is a bilstein group brand