



# Exhaust gas flaps

Extended program (electrical, pneumatic, motor bicycle)



Product selection

Exhaust gas flaps are an important element in modern engines for emission control and increased comfort. They direct the exhaust gas into different exhaust tracts depending on the operating state. Stricter legal requirements governing the control of emissions, in particular, mean that exhaust gas flaps are increasingly being used close to the engine in series production:

- DeNO<sub>x</sub> catalytic converters
- Low-pressure exhaust gas recirculation
- HC adsorber

### Further possible uses:

- Acoustic optimisation of the exhaust tract (e.g. cylinder shut-off)
- Improvement in performance due to resonance effects
- Reduced noise
- Use in the heating system
- Register turbocharging

### Load profile:

- - 40 °C to 950 °C gas temperature
- External tightness: max. 1 l/min (at 20 °C, Δp = 300 mbar)
- Internal tightness: max. 30 kg/h (at 20 °C, Δp = 300 mbar)
- Installation location: close to the engine, in the underbody area, not splash-proof
- Durability: 1,000,000 working cycles

Exhaust gas flaps are an interesting component for vehicle tuners and retrofitters in particular.

### Example: Optimising the acoustics

For this application, the sound waves in the exhaust tract so that they wipe each other out (noise reduction) or amplify each other.



Retrofit in Ferrari 360

### Example: Register turbocharging

With register turbocharging, one turbocharger is optimised for low to medium engine speeds, the second for medium to high engine speeds. The exhaust gas flap controls the exhaust gas supply to the relevant turbocharger.

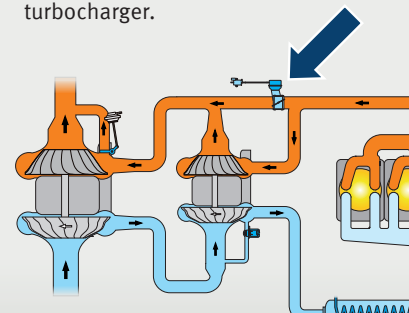

Register turbocharging (schematic)



## Universal use exhaust gas flaps (pneumatic)

PIERBURG no.	Height	Width	Flap Ø	Inner Ø	Outer Ø	Connection angle	Tube angle	Zero position	Comment
	<b>A</b>	<b>B</b>	<b>C</b>	<b>D<sub>1</sub></b>	<b>D<sub>2</sub></b>	<b>R</b>	<b>F</b>	<b>(Unpressurised)</b>	
7.00509.03.0	133.5	137.2	60	63.4	–	180°	90°	Open	
7.00509.05.0			60	63.4	–	180°	90°	Open	Without actuator
7.03204.01.0	141.5	121.15	48	52.8	–	270°	90°	Open	
7.22469.06.0	149 <sup>1)</sup>	114.7 <sup>1)</sup>	47	–	2)	63°	90°	Open	With end tube, see Fig.
7.22525.50.0	133.5	137.2	60	63.4	–	180°	90°	Closed	<sup>3)</sup>
7.22825.03.0	159.8	167.5	71	71	76.1	180°	-17°	Open	Thin-walled tube <sup>3)</sup>
7.28153.16.0	128.9	124	52	55.6	56	153°	90°	Open	<sup>3)</sup>

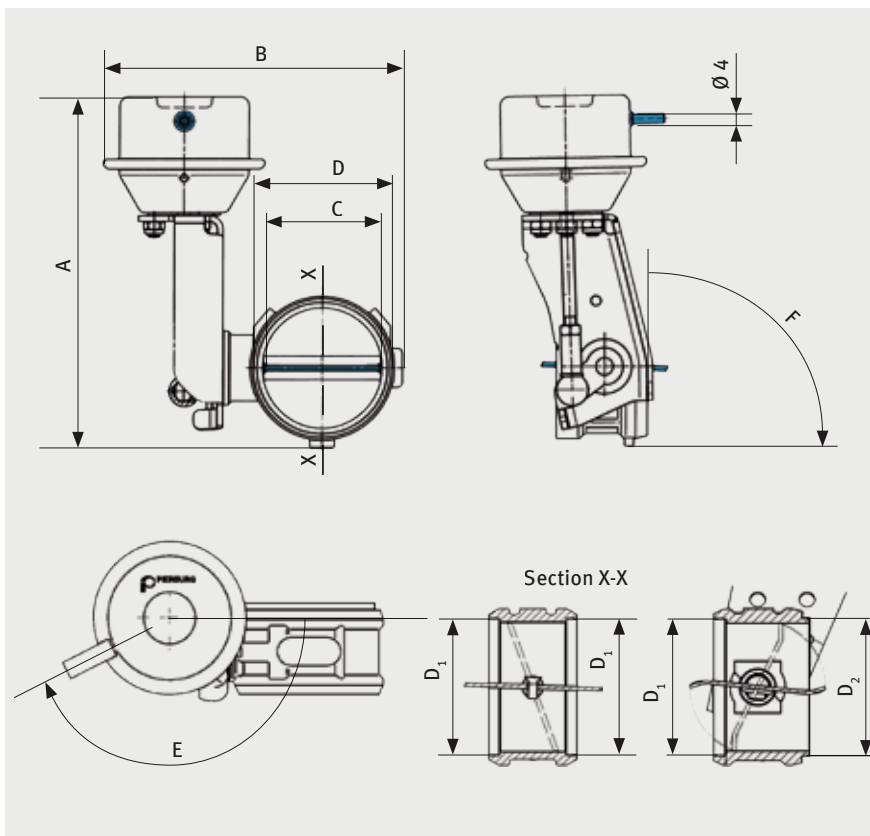

All data in mm

1) Dimensions in flap area

2) With end tube: Inlet side Ø 48.1

3) Available for delivery until exhaustion of stock, please check availability



Exhaust gas flap 7.22469.06.0 with extended connecting tube

### Dimensions

A vacuum is required to operate a pneumatic exhaust gas flap (e.g. from the intake manifold or a vacuum pump). We recommend an electric switchover valve for the actuation (see fig. to the right).

Motorservice offers a wide range of electric switchover valves, such as:

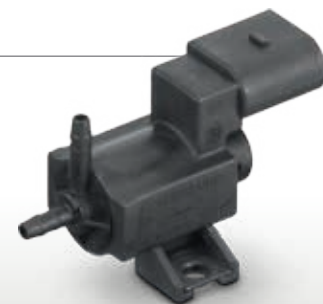

- 7.02318.01.0  
Connection: Junior Timer 2-pin or EV1
- 7.28098.04.0  
Connection: RD clutch



Electric switchover valve

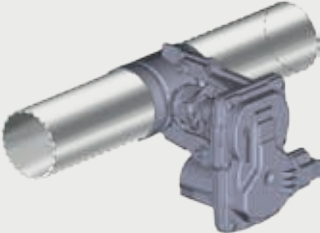

## Vehicle-related exhaust gas flaps (electrical)

<b>A</b> Exhaust gas flap with exhaust pipe (complete) 	<b>B</b> Separate exhaust gas flap as replacement, i.e. the old exhaust gas flap must be separated from the tube and the new exhaust gas flap welded on 	<b>C</b> Electric drive module of the exhaust gas flap as repair kit 
---	---	---

Vehicles	Ref. no.*	Ref. no.*	PIERBURG no.	Ref. no.*	PIERBURG no.
Renault	14 72 506 83R	14 7B 074 24R	7.03571.16.0	14 72 532 72R 14 72 538 28R 14 7B 057 25R	7.03083.20.0
	14 72 532 72R				
	14 72 582 71R				
	20 01 089 45R				
Mercedes-Benz	A 176 490 06 81	–		–	
Nissan	20010-BB60A	147B0-8010WW		–	
	20010-BB60B				
	20010-4EA3A				
	20010-4EA3B				
VAG	–	1K0 253 291 J	7.01300.24.0	–	–
	5Q0 253 101 AG	5Q0 253 691 F	7.03608.16.0	5Q0 253 692 5Q0 253 692 A	7.07696.00.0
	5Q0 253 101 AJ				
	5Q0 253 101 AN				
	5Q0 253 101 AD				
	5Q0 253 101 AC				
	5Q0 253 101 AF				
	5Q0 253 101 AG				
	5Q0 253 101 AH				
	5Q0 253 101 AM				
	3Q0 253 101 AS				
	3Q0 253 101 QX				
	3Q0 253 101 PX				
	3Q0 253 101 MX				
	3Q0 253 101 RX				
	4G0 254 400 GX				
Mazda	–	S550-13J40	7.05662.07.0		
Perkins	–	3629021	7.04209.06.0	–	–
	–	2629023	7.04210.06.0	–	–



## Universal use exhaust gas flap (electrical)

PIERBURG no.	Height	Width	Flap Ø	Outer Ø	Tube angle	Zero position (De-energised)	Comment
	A	B	C	D	F		
7.04174.01.0	166.8	133.3	57.8	77.2	90°	Open	

The electrical exhaust gas flap 7.04174.01.0 is infinitely adjustable in the entire adjustment range between open and closed. A noncontact sensor provides feedback on the flap position.

Position control electronics are not part of the exhaust gas flap. A separate control unit (H-bridge DC engine) is required for application-specific actuation. In this case, please contact our Product Management team.

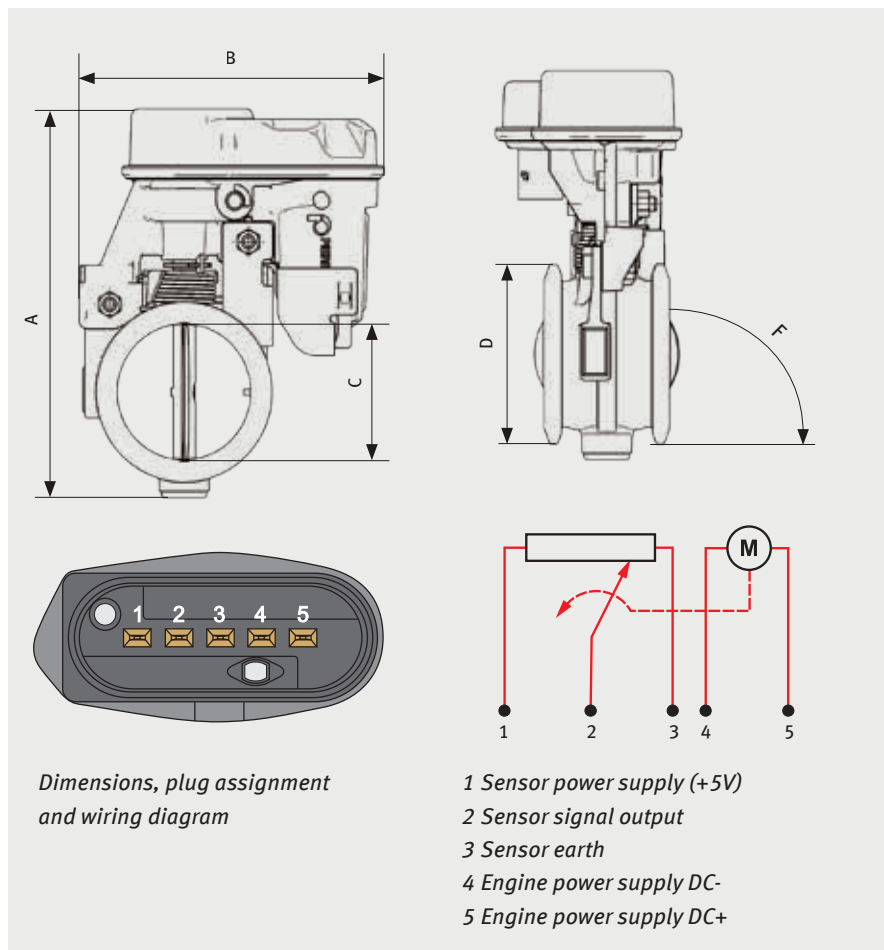

7.04174.01.0



## Exhaust gas flaps on the motor bicycle (externally electrically controlled)

The exhaust gas flap in the motor bicycle

- reduces the flow area in the low to medium engine speed range for increased dynamic pressure. This increases the cylinder charging and therefore also the torque.
- by releasing the full tube cross-section in the upper engine speed range for maximum performance and sporty sound.

Manufacturer	Ref. no.*	PIERBURG no.
BMW	18 12 7 718 415, 18 12 7 710 883	7.01796.13.0 <sup>1)</sup>
	18 12 8 521 881	7.01947.12.0 <sup>2)</sup>

<sup>1)</sup> Separate exhaust gas flap as replacement, i.e. the old exhaust gas flap must be separated from the tube and the new exhaust gas flap welded on.

<sup>2)</sup> Exhaust gas flap with exhaust pipe (complete)



7.01796.13.0



7.01947.12.0