

VKMA 03244

VKMC 03244



A

- (5): CIT. 7014-TJ / PEU. 0153N
- (6): CIT. / PEU. 0188H (Ø 6 mm)
- (7): CIT. / PEU. 0188E (M8x80x125)
- (11): CIT. / PEU. 0188K
- (13): CIT. CTG 105.5 M 4122-T / PEU. SEEM C.Tronic type 1055
- (14): CIT. / PEU. 0188J

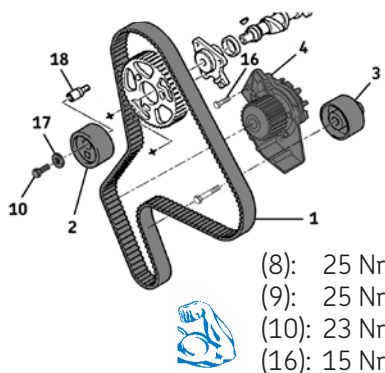

B

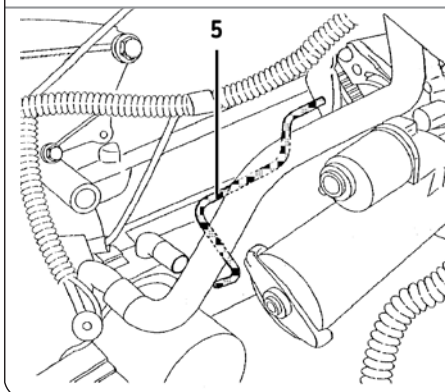

C

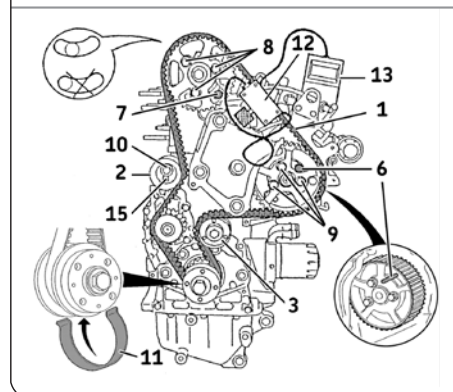

Removal

- 1) Disconnecting the battery according to the vehicle manufacturing guidelines.
- 2) Prepare the vehicle for the timing replacement according to the vehicle manufacturing guidelines.
- 3) Turn the crankshaft in the engine rotation direction until the timing pin (5) can be inserted in the flywheel (Fig. B).
- 4) Insert pin (6) in the injection pump hub and pin (7) in the camshaft hub (Fig. C).
- 5) Loosen the camshaft and injection pump sprocket fastening bolts (8) and (9) (Fig. C).
- 6) Loosen the tensioner roller (2) fastening bolt (10) (Fig. C).
- 7) Remove timing belt (1), tensioner roller (2) and idler roller (3).
- 8) **Removing the water pump (4) (for VKMC 03244):** firstly, bleed the cooling circuit, check it is clean, and clean if required; secondly, fully loosen the water pump fastening bolts (16) and remove the pump (4) (Fig. A).

Refitting

Caution! First thoroughly clean the bearing surfaces of the rollers.

- 9) **Refitting the water pump:** Firstly, fit the new water pump (4), tighten the waterpump bolts (16) to the torque **15 Nm**, then check that the water pump pulley runs properly, and has no hard or locking spots.
- 10) Fit the new tensioner roller (2), and tighten its new bolt (10) with its new washer (17) by hand (Fig. A). Fit the new idler roller (3).

Note: Take care to get the surface of the tensioner roller (2) aligned with the top of the mounting pin (18) (Fig. E).

- 11) Slightly tighten the camshaft and injection pump sprocket fastening bolts (8) and (9) (Fig. C).
- 12) Move the camshaft and injection pump sprockets to the end of the oblong holes by turning them in the engine rotation direction.
- 13) Place the new timing belt (1) on the crankshaft sprocket and immobilize with tool (11) (Fig. C).

D

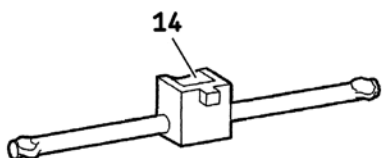

Install Confidence

VKN 1009



- 14) Continue fitting the timing belt (1) in the following order: idler roller (3), injection pump sprocket, camshaft sprocket, water pump sprocket and tensioner roller (2).

Note: To help place the belt on the camshaft and injection pump sprockets, turn the sprockets slightly in an anti-clockwise direction. The angular displacement of the sprockets relative to the belt must not exceed one half tooth.

- 15) Place the sensor (12) of the tension gauge (13) on the belt (1) between the camshaft and injection pump sprockets (Fig. C).
- 16) Tighten the timing belt: Insert the tool (14) (Fig. D) in the hole (15) and turn the tensioner roller (2) anti-clockwise until a reading of 106 SEEM units is displayed on the tension gauge (13) (Fig. C).
- 17) Check that the camshaft and injection pump sprockets are not touching the ends of the oblong holes.
- 18) Tighten the fastening bolt (10) of the tensioner roller (2) to 23 Nm. Tighten the sprocket fastening bolts (8) and (9) to 25 Nm (Fig. C).
- 19) Remove the sensor (12) (Fig. C).
- 20) Remove the tool (11) (Fig. C) and all the pins.
- 21) Turn the crankshaft through 8 revolutions in the engine rotation direction until pins (5), (6) and (7) can be inserted (Fig. B & Fig. C).
- 22) Loosen the camshaft and injection pump sprocket fastening bolts (8) and (9) as well as that of the tensioner roller (2) (Fig. C).

- 23) Slightly retighten fastening bolts (8) and (9) (Fig. C).
- 24) Place the sensor (12) on the belt (1) (Fig. C).
- 25) Insert the tool (14) (Fig. D) in the hole (15) and turn the tensioner roller (2) anti-clockwise until a reading of 42 SEEM units is displayed on the tension gauge (13) (Fig. C).
- 26) Repeat the step 18).
- 27) Remove the sensor (12), check the tension, then refit the sensor (12) and check that the tension reading is between 38 and 46 SEEM units (Fig. C).
- 28) If the tension reading is not between 38 and 46 SEEM units, re-start the tension adjustment operation from step 15).
- 29) Remove the sensor (12) (Fig. C).
- 30) Remove the timing pins (5), (6), and (7) (Fig. B et Fig. C).
- 31) Turn the crankshaft through 2 revolutions in the engine rotation direction until pins (5), (6) and (7) can be inserted (Fig. B and Fig. C).
- 32) Remove the timing pins (5), (6) and (7).
- 33) Refit the removed elements in reverse order to removal.
- 34) Fill the cooling circuit with the permanent fluid recommended.
- 35) Check the circuit's leak-tightness when the engine reaches its running temperature and secure the level of coolant when the engine is at ambient temperature (20 °C).

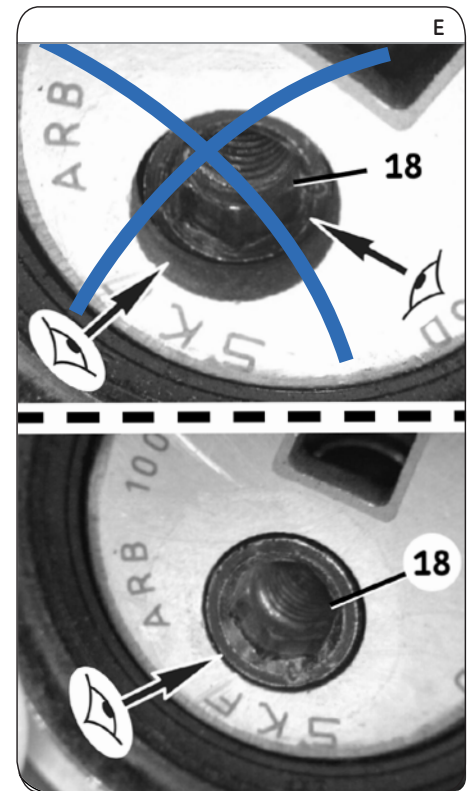

Notice: Always follow the vehicle manufacturer instructions when working on the engine. The SKF KITS are designed for the automotive repair professional and must be fitted using tooling used by these professionals. These instructions are to be used as a guideline only. This document is the exclusive property of SKF. Any representation, partial or full reproduction, is forbidden without prior written consent from SKF.