



Technical Report #44

VAG 56003500 cylinder head cover gasket kit assembly

Technical Report

Purpose

Instructions for the correct assembly of the cylinder head cover gaskets for VAG petrol V6 2.4 and 2.7 liters. Specifications and tighten procedure.

Description

This part number fits on V6 engines, so one engine will need 2 gasket kits, one for each cylinder head.

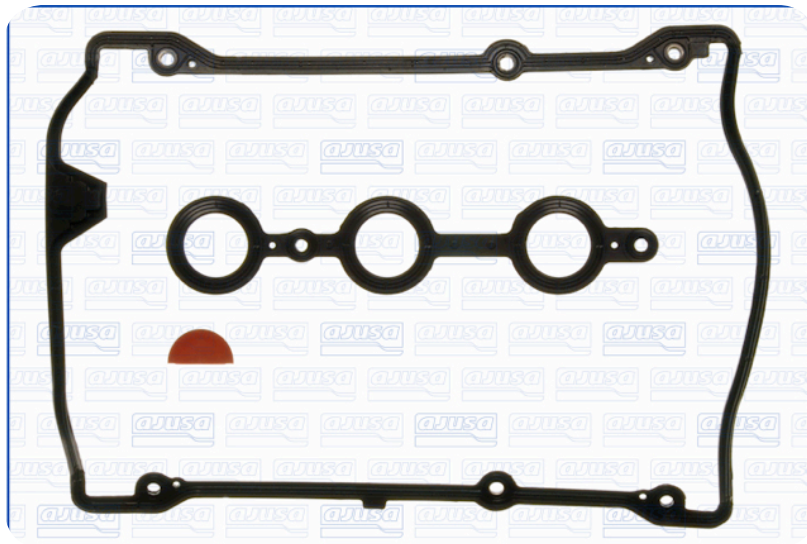

Applicable engines and models:

MAKER	MODEL	C.C.	ENGINE TYPES
AUDI	A4 V6 30V	2.393	ALF, AML, AMM, BDV, AGA, AJG, APS, APZ, ARJ
		2.771	ACK, ALG, AMX, APR, AQD, ATX, ACK
	A6 V6 30V	2.393	AMM, AML, BDV, AGA, AJG, APZ, APC, ALF, ALW, ARJ, APS, ARN, ASM
		2.671	AJK, ARE, AZA, BES
		2.771	AMX, APR, AQD, ATX, ACK, AGE, ALG
		2.771	ACK, APR, AQD, ATX, AMX, ACK, ALG
	ALLROAD QUATTRO V6 TURBO 30V	2.671	ARE
	RS4 TURBO V6 30V	2.671	ASJ, AZR
S4 V6 30V	2.671	AGB, AZB	
S6 V6 30V	2.671	AJK	
VOLKSWAGEN	PASSAT GL/GLS/GLX V6 30V	2.771	ATQ
	PASSAT V6 30V	2.771	AGE, ACK, APR, AQD, ALG, ATX, BBG, AMX, ATQ
SKODA	SUPERB V6 30V	2.771	AMX, BBG

* For further information about the applicable models of these gaskets please check our General Catalogue.

Assembly

1. Clean all surfaces before installing the new gasket. Install the new gasket with special attention where the gasket fits into the slots on the sides of the cylinder head.

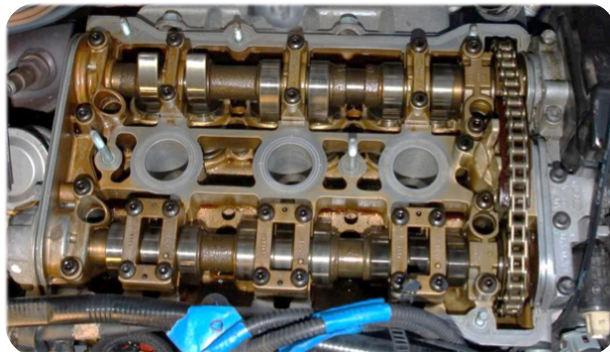

2. Apply sealant (Ajusil) in the transition area of the caps in the cylinder head as shown in the repair manual.

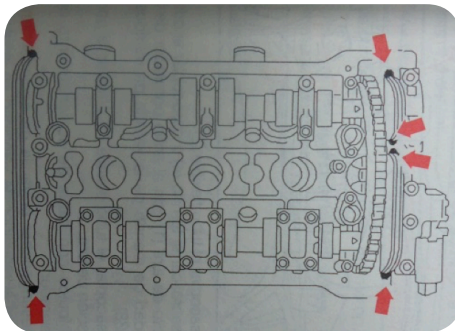

NOTE: To ensure the correct sealing of the cylinder head cover gasket, is absolutely necessary the application of this small quantity of silicone sealant over the mentioned transition areas.

3. Tighten the nuts of the rocker cover always following the specified torque.

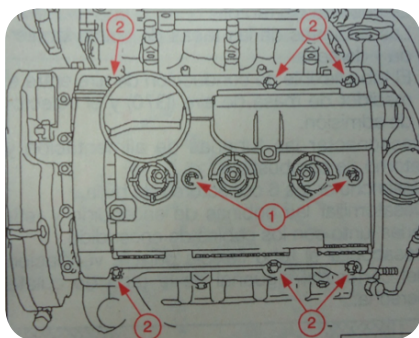

- Start tightening the nuts on the outside of the cover (2) crosswise

- Then tighten the center (1)

- Torque 1 kpm