

Sachgemäßer Einbau Correct installation

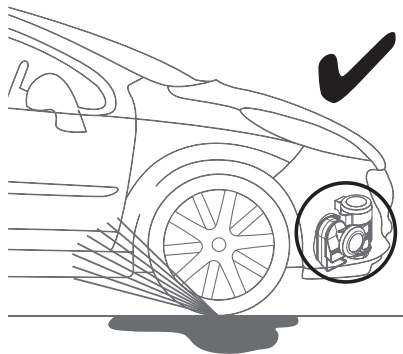

Unsachgemäßer Einbau Improper installation

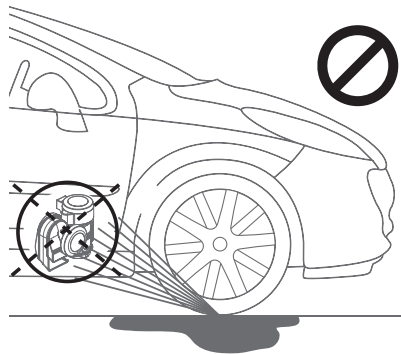

Montageskizze - Mounting diagram

Frontansicht
Frontal view

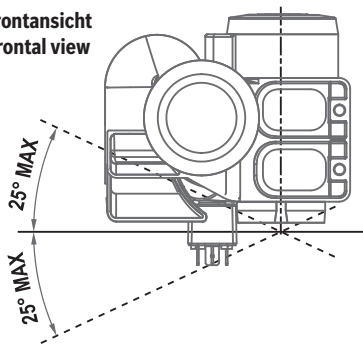

Seitenansicht
Lateral view

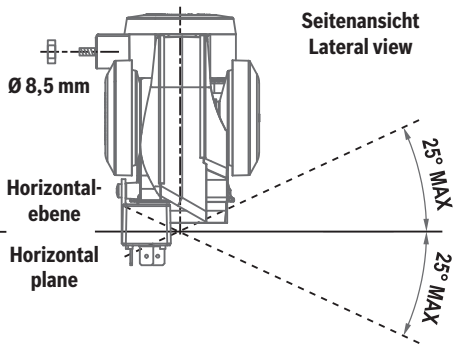

Anschlussdiagramm – Wiring Diagram

Montage des Airmasters als zusätzliche Hupe – Horn mounted in addition to normal horn

Anschlussdiagramm mit positivem Pol am Schalter Hupe
– Wiring diagram with positive terminal to horn button

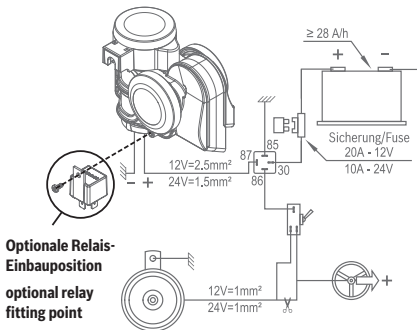

Anschlussdiagramm mit an der Fahrzeugkarosserie geerdetem Pol am Schalter Hupe
– Wiring diagram with ground lead to horn button

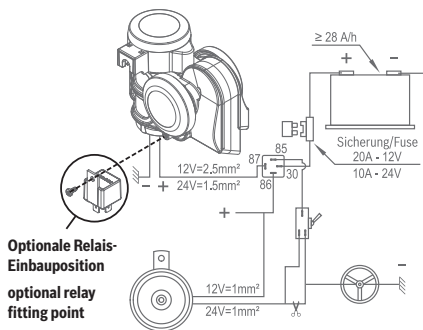

Montage des Airmasters als Ersatz der bisherigen Hupe – Horn mounted instead of normal horn

Anschlussdiagramm mit positivem Pol am Schalter Hupe
– Wiring diagram with positive terminal to horn button

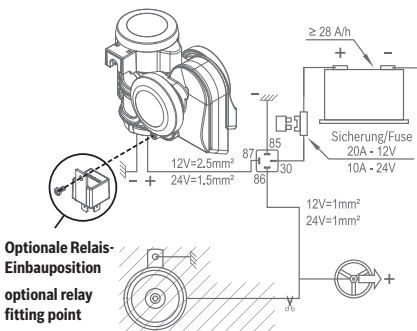

Anschlussdiagramm mit an der Fahrzeugkarosserie geerdetem Pol am Schalter Hupe
– Wiring diagram with ground lead to horn button

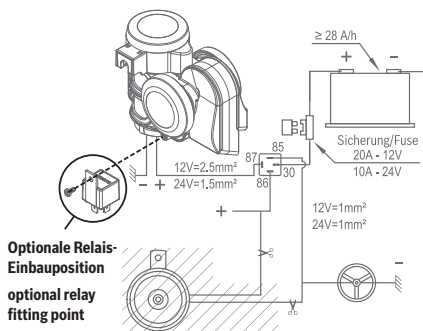

Tonbeispiel - Sound sample

